

Service Bulletin # 170

DATE: February 8, 1974

MODELS: DN100-5; DN145-5; DN204-6 and DN246-6

SUBJECT: Evaporator Fan Motor Brace.

REASON: To provide a Brace to correct the problem of Fan Blade "Hang Up", if it should occur.

ORDER AS: B/M164,012,100.04 Brace Kit for Fan Motor

KIT CONSISTS OF: 1 A164,010,140.03 Brace, Fan Motor
2 900,600,230.02 Sheet Metal Screw, #8 x 1/2"

TO INSTALL, DO THIS:

1. Remove the bottle/can chute.
2. Locate the fan motor Brace as shown, Fig. 1.
Caution: See C (Center Line) location of the Brace as related to fan motor and fan motor bracket.
3. Drill two (2) 1/8" holes (using Brace as a marking template), through tank back. Use 1/8" drill bit.
4. Secure the fan motor Brace with the two (2) Sheet Metal Screws provided.

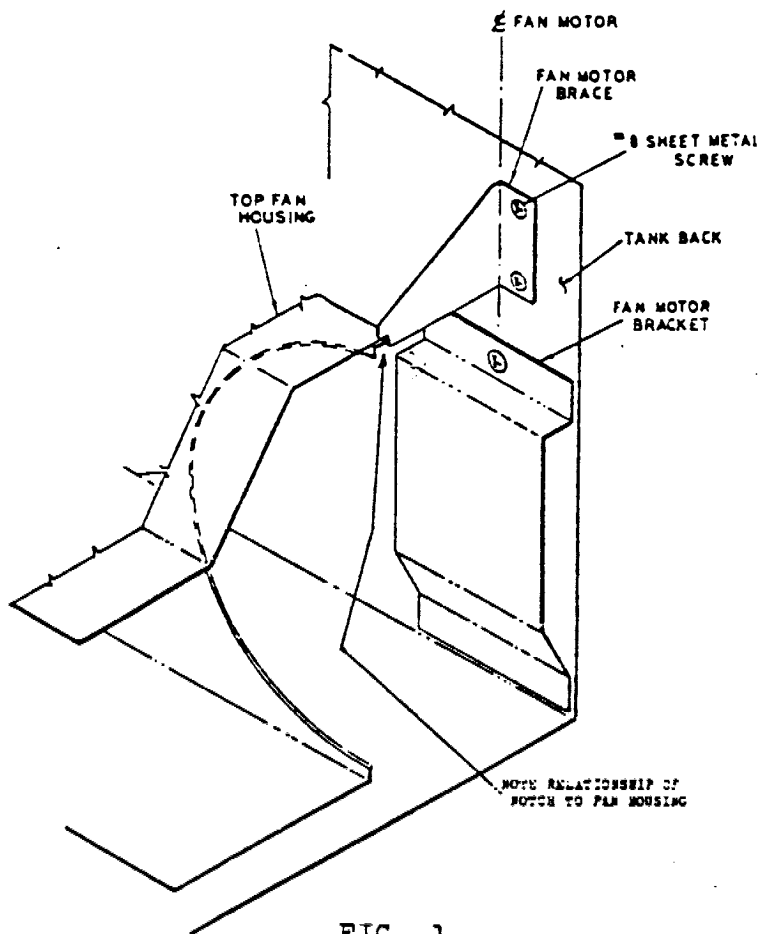

FIG. 1